

LME49721

High Performance, High Fidelity Rail-to-Rail Input/Output Audio Operational Amplifier

General Description

The LME49721 is a low distortion, low noise Rail-to-Rail Input/Output operational amplifier optimized and fully specified for high performance, high fidelity applications. Combining advanced leading-edge process technology with state-of-the-art circuit design, the LME49721 Rail-to-Rail Input/Output operational amplifier delivers superior signal amplification for outstanding performance. The LME49721 combines a very high slew rate with low THD+N to easily satisfy demanding applications. To ensure that the most challenging loads are driven without compromise, the LME49721 has a high slew rate of $\pm 8.5\text{V}/\mu\text{s}$ and an output current capability of $\pm 9.7\text{mA}$. Further, dynamic range is maximized by an output stage that drives $10\text{k}\Omega$ loads to within 10mV of either power supply voltage.

The LME49721 has a wide supply range of 2.2V to 5.5V . Over this supply range the LME49721's input circuitry maintains excellent common-mode and power supply rejection, as well as maintaining its low input bias current. The LME49721 is unity gain stable.

Key Specifications

■ Power Supply Voltage Range	2.2V to 5.5V
■ Quiescent Current	2.15mA (typ)
■ THD+N ($A_V = 2$, $V_{OUT} = 4V_{p-p}$, $f_{IN} = 1\text{kHz}$)	
$R_L = 2\text{k}\Omega$	0.00008% (typ)
$R_L = 600\Omega$	0.0001% (typ)
■ Input Noise Density	$4\text{nV}/\sqrt{\text{Hz}}$ (typ), @ 1kHz
■ Slew Rate	$\pm 8.5\text{V}/\mu\text{s}$ (typ)

■ Gain Bandwidth Product	20MHz (typ)
■ Open Loop Gain ($R_L = 600\Omega$)	118dB (typ)
■ Input Bias Current	40fA (typ)
■ Input Offset Voltage	0.3mV (typ)
■ PSRR	103dB (typ)

Features

- Rail-to-rail Input and Output
- Easily drives $10\text{k}\Omega$ loads to within 10mV of each power supply voltage
- Optimized for superior audio signal fidelity
- Output short circuit protection

Applications

- Ultra high quality portable audio amplification
- High fidelity preamplifiers
- High fidelity multimedia
- State of the art phono pre amps
- High performance professional audio
- High fidelity equalization and crossover networks
- High performance line drivers
- High performance line receivers
- High fidelity active filters
- DAC I-V converter
- ADC front-end signal conditioning

Typical Connection, Pinout, and Package Marking

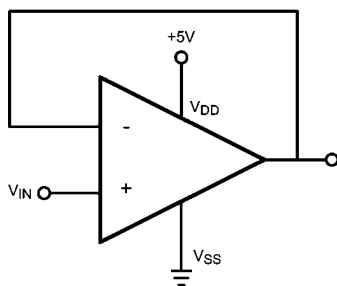
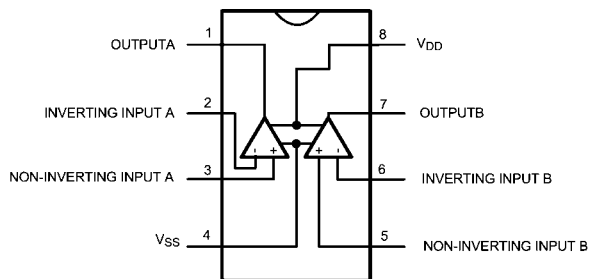
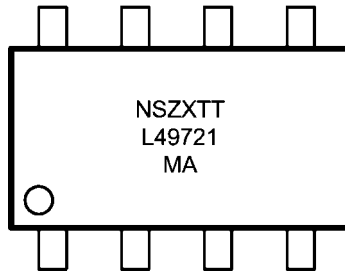

FIGURE 1. Buffer Amplifier 20204909



Order Number LME49721MA
Se NS Package Number M08A 20204910

Package Marking



202049x1

- NS = National Logo**
- Z = Assembly plant code**
- X = 1 Digit date code**
- TT = Lot traceability**
- L49721 = LME49721**
- MA = Narrow SOIC package code**

Absolute Maximum Ratings (Notes 1, 2)

If Military/Aerospace specified devices are required, please contact the National Semiconductor Sales Office/ Distributors for availability and specifications.

Power Supply Voltage ($V_S = V^+ - V^-$)	6V
Storage Temperature	-65°C to 150°C
Input Voltage	(V-) - 0.7V to (V+) + 0.7V
Output Short Circuit (Note 3)	Continuous

Power Dissipation	Internally Limited
ESD Rating (Note 4)	2000V
ESD Rating (Note 5)	200V
Junction Temperature	150°C
Thermal Resistance	
θ_{JA} (SO)	165°C/W
Temperature Range	
$T_{MIN} \leq T_A \leq T_{MAX}$	-40°C \leq T_A \leq 85°C
Supply Voltage Range	2.2V \leq V_S \leq 5.5V

Electrical Characteristics for the LME49721 The following specifications apply for the circuit shown in Figure 1. $V_S = 5V$, $R_L = 10k\Omega$, $R_{SOURCE} = 10\Omega$, $f_{IN} = 1kHz$, and $T_A = 25^\circ C$, unless otherwise specified.

Symbol	Parameter	Conditions	LME49721		Units (Limits)
			Typical	Limit	
			(Note 6)	(Note 7)	
THD+N	Total Harmonic Distortion + Noise	$A_V = +1$, $V_{OUT} = 2V_{p-p}$, $R_L = 2k\Omega$ $R_L = 600\Omega$	0.0002 0.0002	0.001	% (max)
IMD	Intermodulation Distortion	$A_V = +1$, $V_{OUT} = 2V_{p-p}$, Two-tone, 60Hz & 7kHz 4:1	0.0004		%
GBWP	Gain Bandwidth Product		20	15	MHz (min)
SR	Slew Rate	$A_V = +1$	8.5		V/ μ s (min)
FPBW	Full Power Bandwidth	$V_{OUT} = 1V_{p-p}$, -3dB referenced to output magnitude at $f = 1kHz$	2.2		MHz
t_s	Settling time	$A_V = 1$, 4V step 0.1% error range	800		ns
e_n	Equivalent Input Noise Voltage	$f_{BW} = 20Hz$ to 20kHz, A-weighted	.707	1.13	μV_{p-p} (max)
	Equivalent Input Noise Density	$f = 1kHz$ A-weighted	4	6	nV/ \sqrt{Hz} (max)
i_n	Current Noise Density	$f = 10kHz$	4.0		fA/ \sqrt{Hz}
V_{OS}	Offset Voltage		0.3	1.5	mV (max)
$\Delta V_{OS}/\Delta Temp$	Average Input Offset Voltage Drift vs Temperature	40°C \leq T_A \leq 85°C	1.1		$\mu V/^\circ C$
PSRR	Average Input Offset Voltage Shift vs Power Supply Voltage		103	85	dB (min)
ISO _{CH-CH}	Channel-to-Channel Isolation	$f_{IN} = 1kHz$	117		dB
I_B	Input Bias Current	$V_{CM} = V_S/2$	40		fA
$\Delta I_{OS}/\Delta Temp$	Input Bias Current Drift vs Temperature	-40°C \leq T_A \leq 85°C	48		fA/ $^\circ C$
I_{OS}	Input Offset Current	$V_{CM} = V_S/2$	60		fA
V_{IN-CM}	Common-Mode Input Voltage Range			(V+) - 0.1 (V-) + 0.1	V (min)
CMRR	Common-Mode Rejection	$V_{SS} - 100mV < V_{CM} < V_{DD} + 100mV$	93	70	dB (min)
	1/f Corner Frequency		2000		Hz
A_{VOL}	Open Loop Voltage Gain	$V_{SS} - 200mV < V_{OUT} < V_{DD} + 200mV$			
		$R_L = 600\Omega$	118	100	dB (min)
		$R_L = 2k\Omega$	122		dB (min)
		$R_L = 10k\Omega$	130	115	dB (min)

Symbol	Parameter	Conditions	LME49721		Units (Limits)
			Typical	Limit	
			(Note 6)	(Note 7)	
V _{OUTMIN}	Output Voltage Swing	R _L = 600Ω	V _{DD} – 30mV	V _{DD} – 80mV	V (min)
			V _{SS} + 30mV	V _{SS} + 80mV	V (min)
		R _L = 10kΩ, V _S = 5.0V	V _{DD} – 10mV	V _{DD} – 20mV	V (min)
			V _{SS} + 10mV	V _{SS} + 20mV	V (min)
I _{OUT}	Output Current	R _L = 250Ω, V _S = 5.0V	9.7	9.3	mA (min)
I _{OUT-SC}	Short Circuit Current		100		mA
R _{OUT}	Output Impedance	f _{IN} = 10kHz			
		Closed-Loop	0.01		Ω
		Open-Loop	46		
I _S	Quiescent Current per Amplifier	I _{OUT} = 0mA	2.15	3.25	mA (max)

Note 1: "Absolute Maximum Ratings" indicate limits beyond which damage to the device may occur, including inoperability and degradation of device reliability and/or performance. Functional operation of the device and/or non-degradation at the *Absolute Maximum Ratings* or other conditions beyond those indicated in the *Recommended Operating Conditions* is not implied. The *Recommended Operating Conditions* indicate conditions at which the device is functional and the device should not be operated beyond such conditions. All voltages are measured with respect to the ground pin, unless otherwise specified

Note 2: The *Electrical Characteristics* tables list guaranteed specifications under the listed *Recommended Operating Conditions* except as otherwise modified or specified by the *Electrical Characteristics Conditions* and/or Notes. Typical specifications are estimations only and are not guaranteed.

Note 3: The maximum power dissipation must be derated at elevated temperatures and is dictated by T_{JMAX}, θ_{JA}, and the ambient temperature, T_A. The maximum allowable power dissipation is P_{DMAX} = (T_{JMAX} - T_A) / θ_{JA} or the number given in *Absolute Maximum Ratings*, whichever is lower.

Note 4: Human body model, applicable std. JESD22-A114C.

Note 5: Machine model, applicable std. JESD22-A115-A.

Note 6: Typical values represent most likely parametric norms at T_A = +25°C, and at the *Recommended Operation Conditions* at the time of product characterization and are not guaranteed.

Note 7: Datasheet min/max specification limits are guaranteed by test or statistical analysis.

Typical Performance Characteristics Graphs were taken in dual supply configuration.

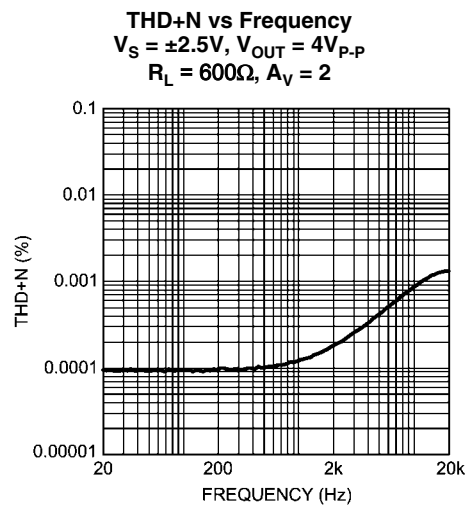
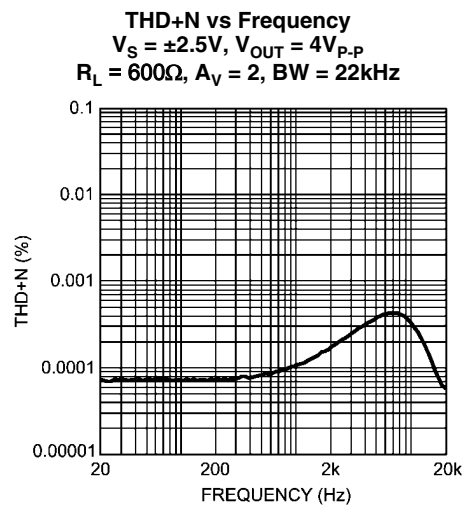
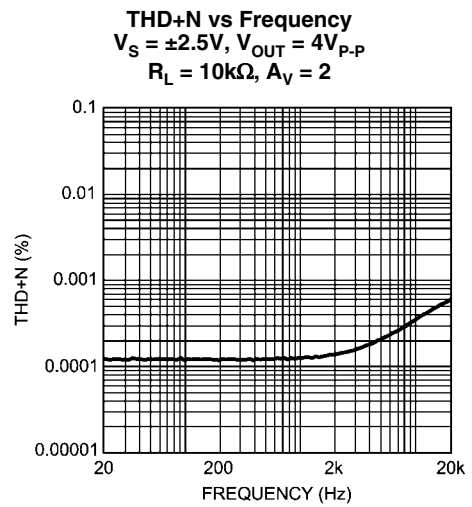
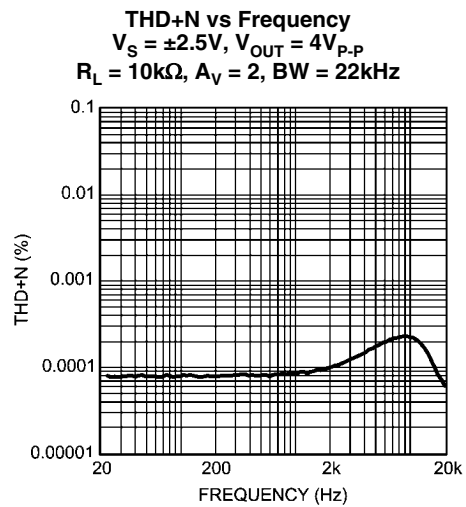
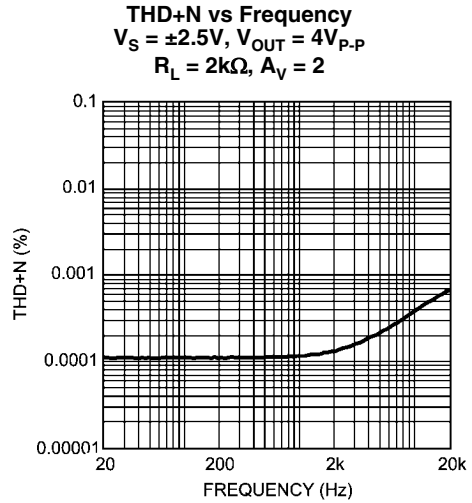
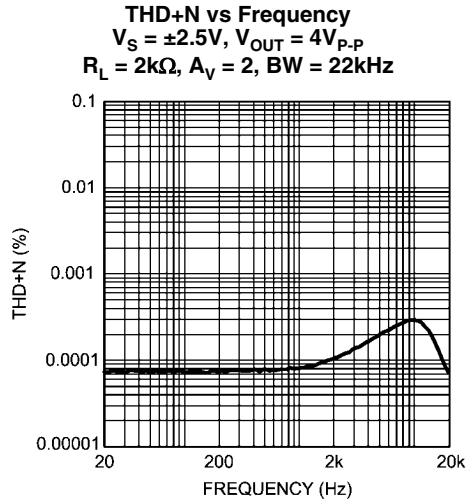

THD+N vs Frequency
 $V_S = \pm 2.75V, V_{OUT} = 4V_{P-P}$
 $R_L = 2k\Omega, A_V = 2, BW = 22kHz$

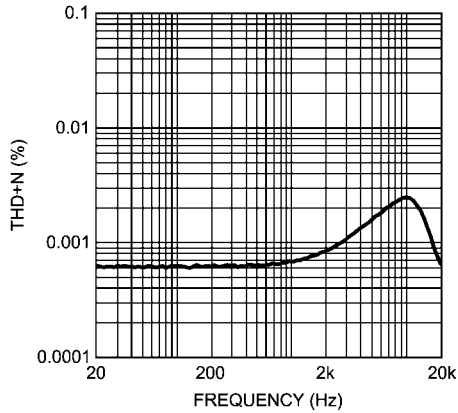

202049u2

THD+N vs Frequency
 $V_S = \pm 2.75V, V_{OUT} = 4V_{P-P}$
 $R_L = 2k\Omega, A_V = 2$

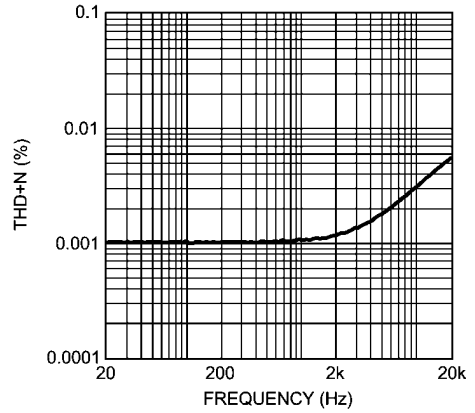

202049u1

THD+N vs Frequency
 $V_S = \pm 2.75V, V_{OUT} = 4V_{P-P}$
 $R_L = 10k\Omega, A_V = 2, BW = 22kHz$

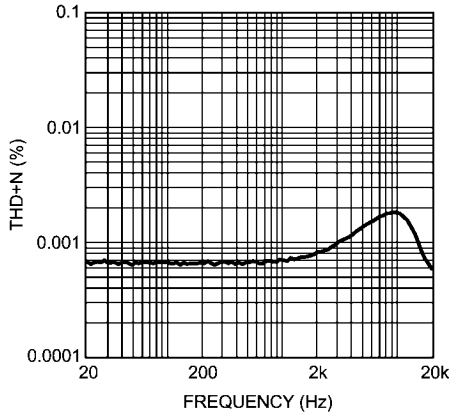

202049u4

THD+N vs Frequency
 $V_S = \pm 2.75V, V_{OUT} = 4V_{P-P}$
 $R_L = 10k\Omega, A_V = 2$

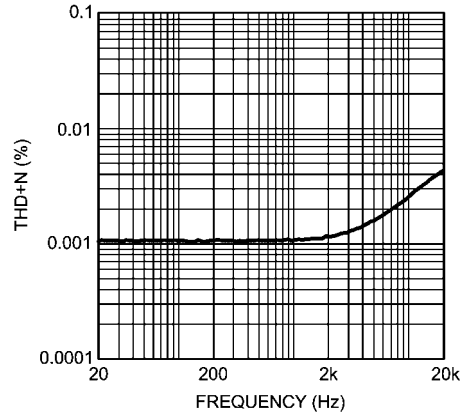

202049u3

THD+N vs Frequency
 $V_S = \pm 2.75V, V_{OUT} = 4V_{P-P}$
 $R_L = 600\Omega, A_V = 2, BW = 22kHz$

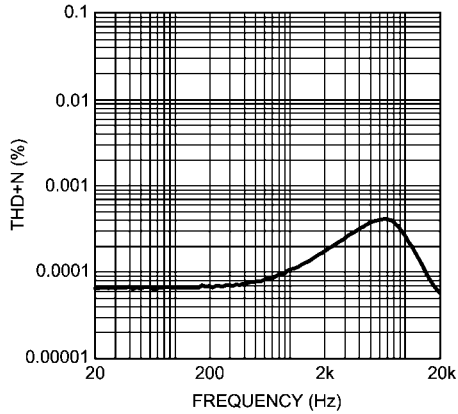

202049u5

THD+N vs Frequency
 $V_S = \pm 2.75V, V_{OUT} = 4V_{P-P}$
 $R_L = 600\Omega, A_V = 2$

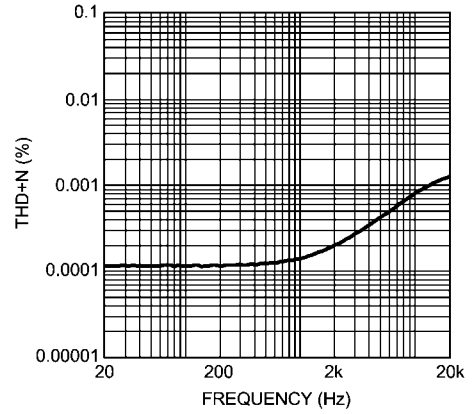

202049u6

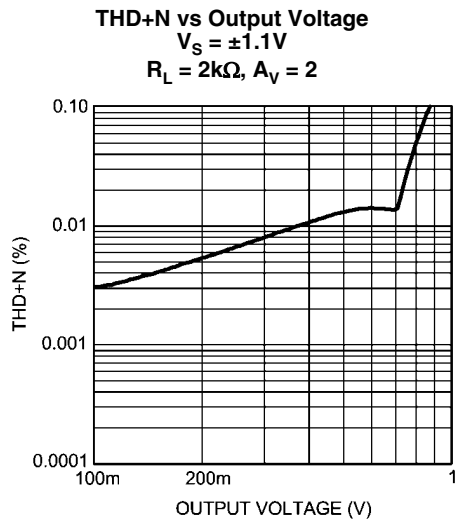

202049u7

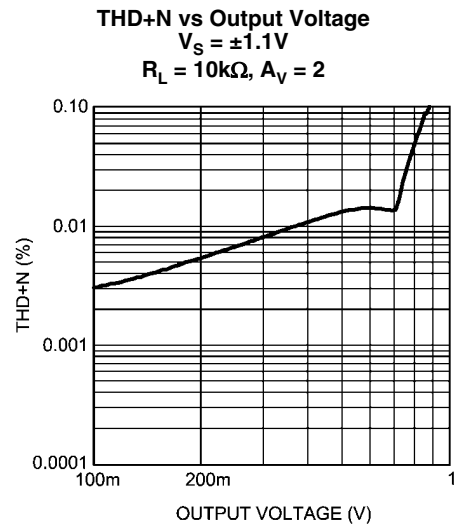

202049u8

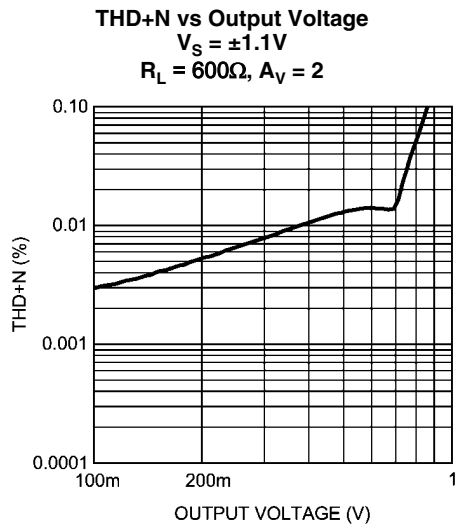

202049u9

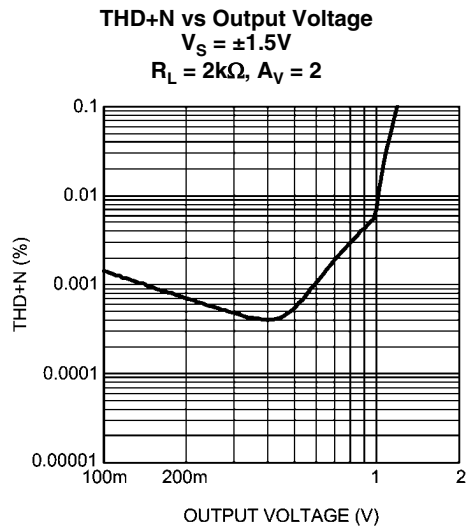

202049v0

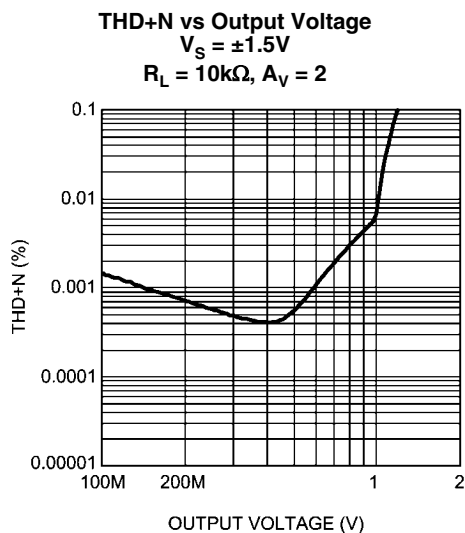

202049v1

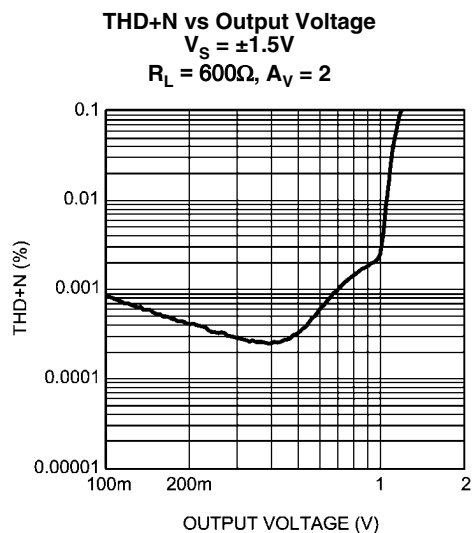

202049v2

THD+N vs Output Voltage
 $V_S = \pm 2.5V$
 $R_L = 2k\Omega, A_V = 2$

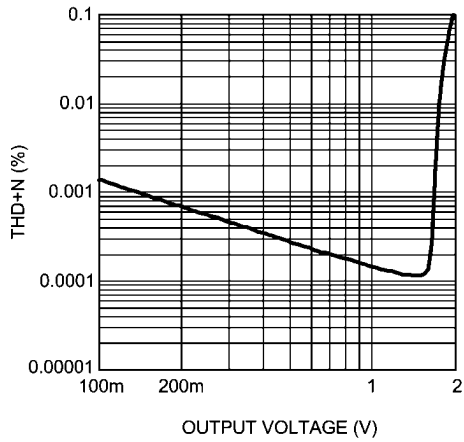

202049v3

THD+N vs Output Voltage
 $V_S = \pm 2.5V$
 $R_L = 10k\Omega, A_V = 2$

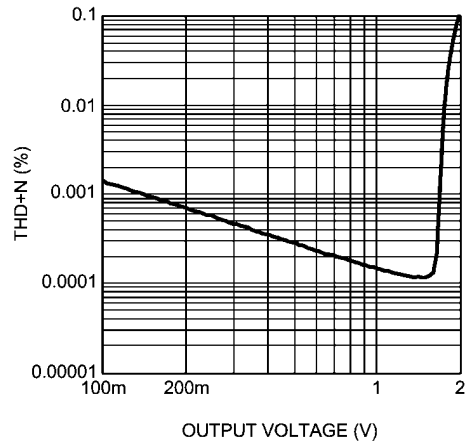

202049v4

THD+N vs Output Voltage
 $V_S = \pm 2.5V$
 $R_L = 600\Omega, A_V = 2$

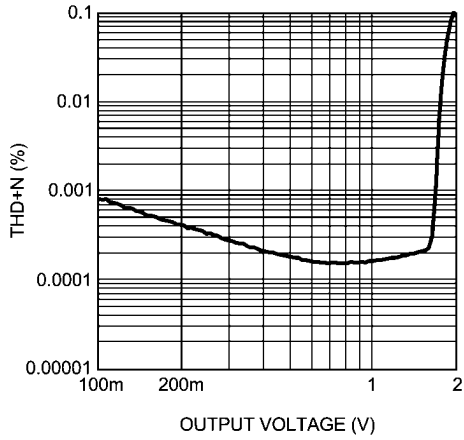

202049v5

THD+N vs Output Voltage
 $V_S = \pm 2.75V$
 $R_L = 2k\Omega, A_V = 2$

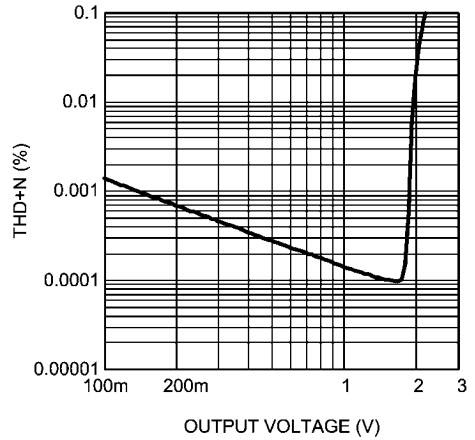

202049v6

THD+N vs Output Voltage
 $V_S = \pm 2.75V$
 $R_L = 10k\Omega, A_V = 2$

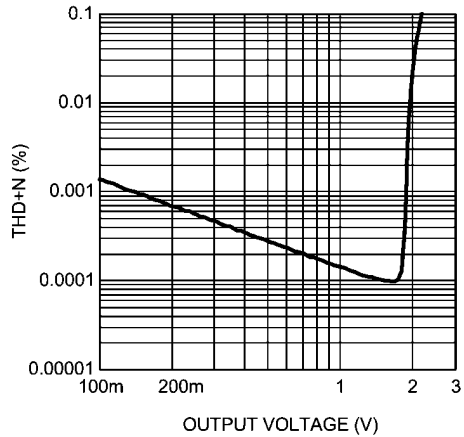

202049v7

THD+N vs Output Voltage
 $V_S = \pm 2.75V$
 $R_L = 600\Omega, A_V = 2$

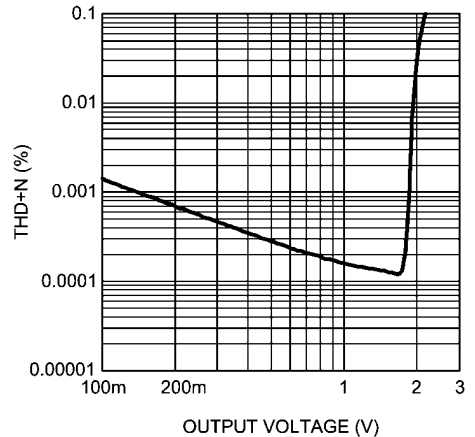

202049v8

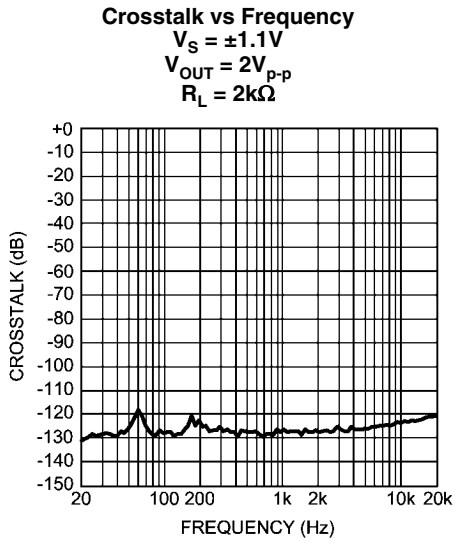

202049r4

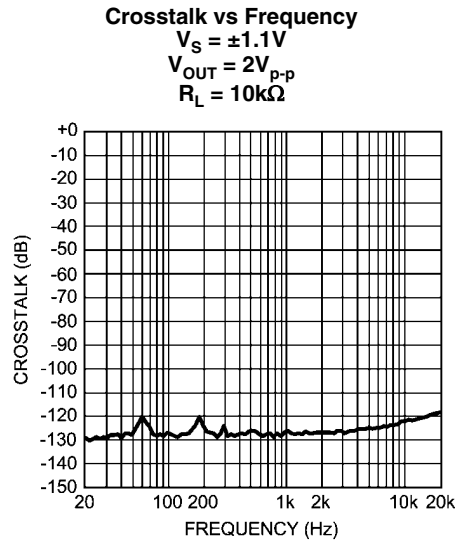

202049r5

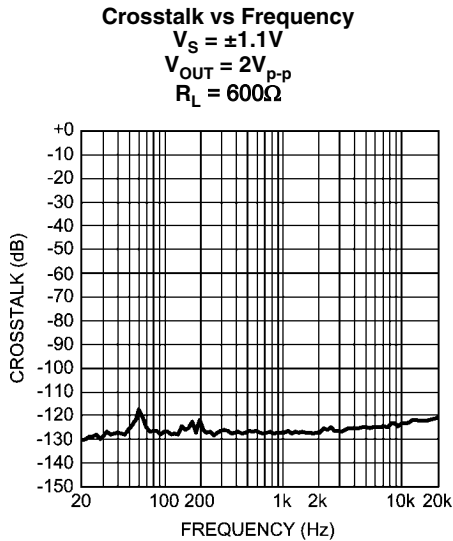

202049r6

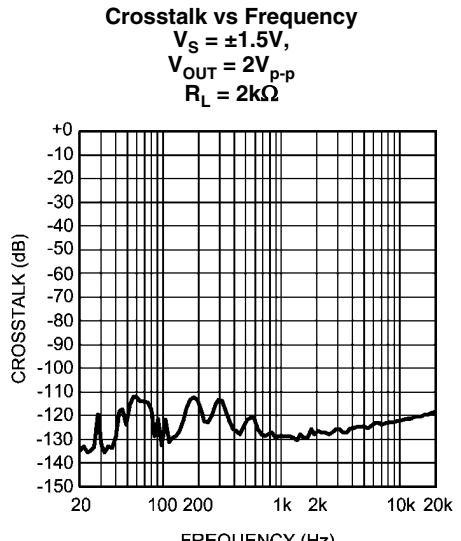

202049k1

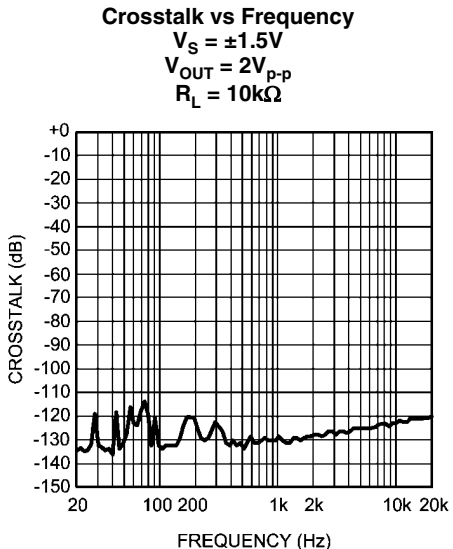

202049k2

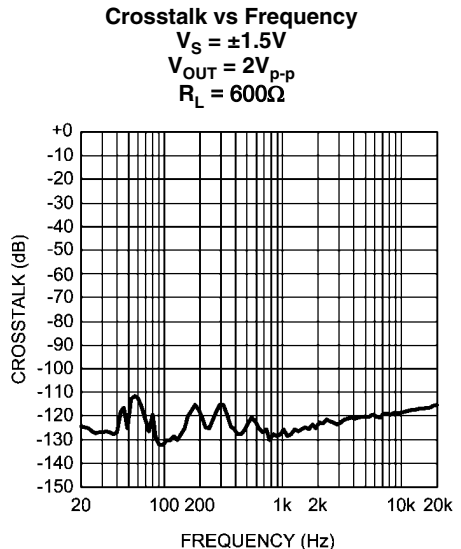

202049k3

Crosstalk vs Frequency

$V_S = \pm 2.5V$
 $V_{OUT} = 4V_{p-p}$
 $R_L = 2k\Omega$

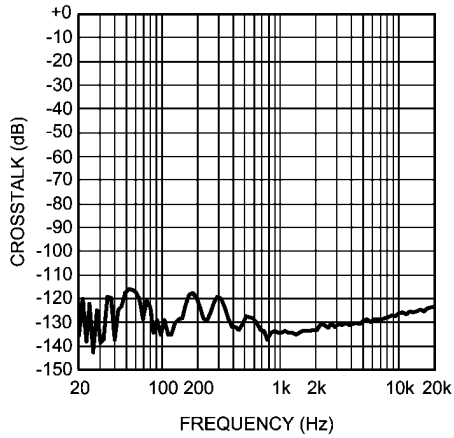

202049k4

Crosstalk vs Frequency

$V_S = \pm 2.5V$
 $V_{OUT} = 4V_{p-p}$
 $R_L = 10k\Omega$

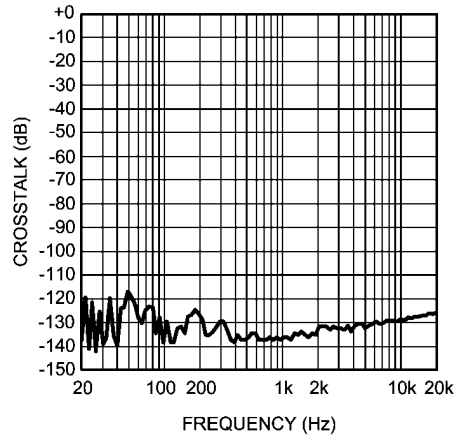

202049k5

Crosstalk vs Frequency

$V_S = \pm 2.5V$
 $V_{OUT} = 4V_{p-p}$
 $R_L = 600\Omega$

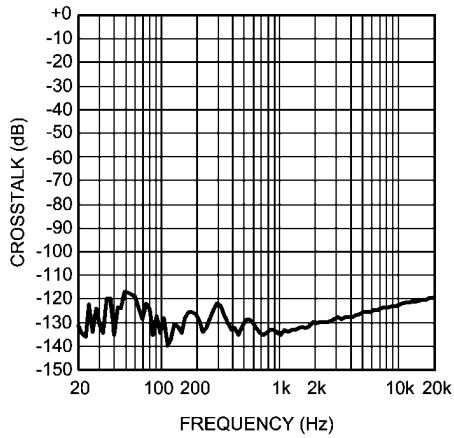

202049k6

Crosstalk vs Frequency

$V_S = \pm 2.75V$
 $V_{OUT} = 4V_{p-p}$
 $R_L = 2k\Omega$

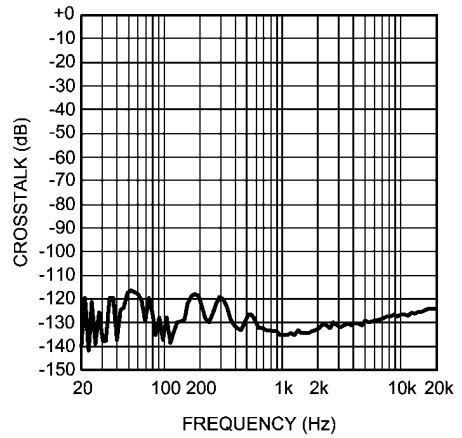

202049k7

Crosstalk vs Frequency

$V_S = \pm 2.75V$
 $V_{OUT} = 4V_{p-p}$
 $R_L = 10k\Omega$

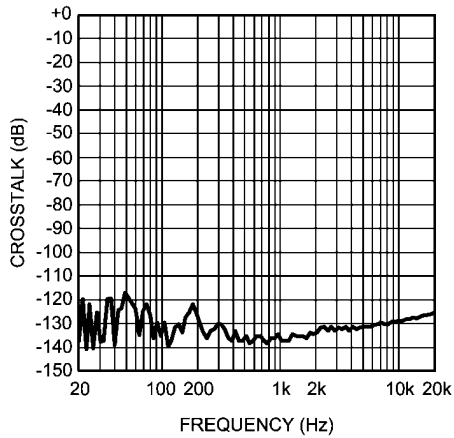

202049k8

Crosstalk vs Frequency

$V_S = \pm 2.75V$
 $V_{OUT} = 4V_{p-p}$
 $R_L = 600\Omega$

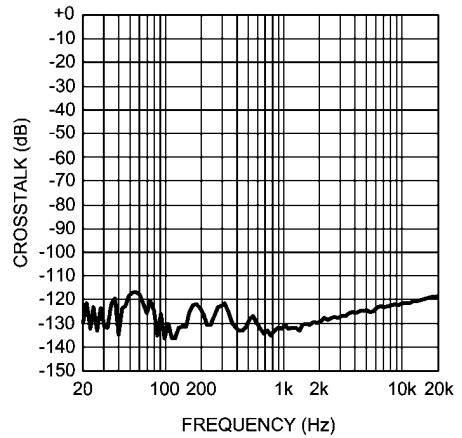

202049k9

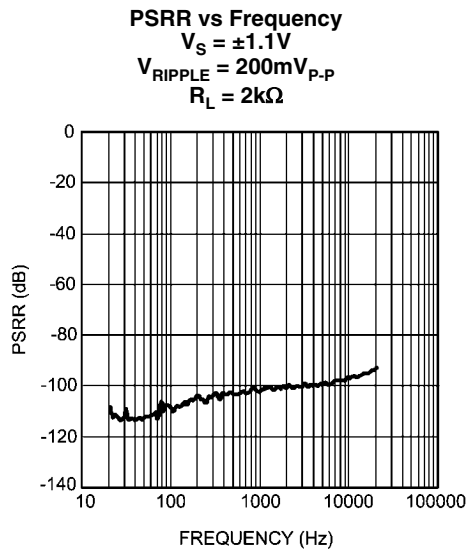

202049v9

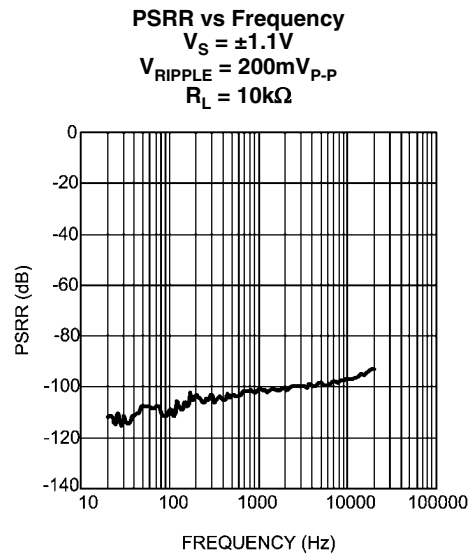

202049w0

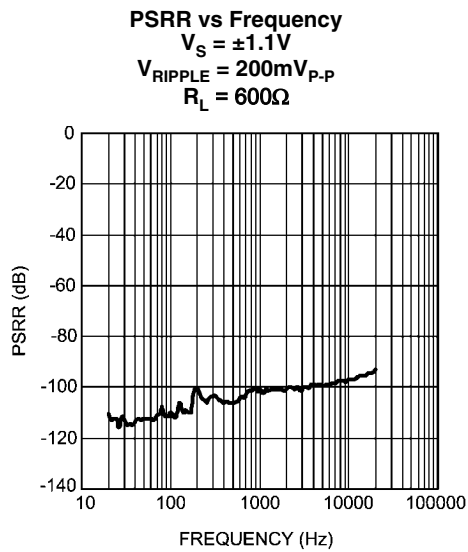

202049w1

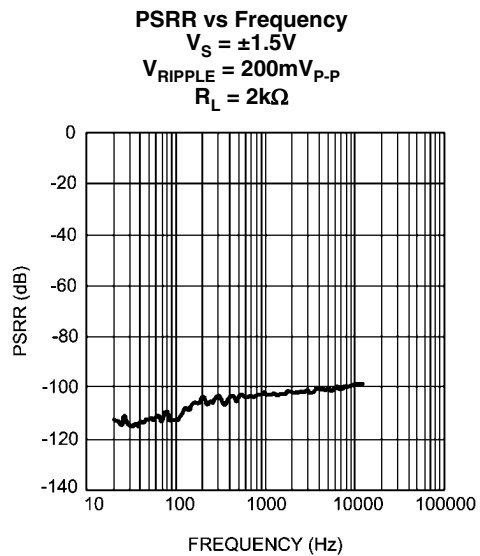

202049w2

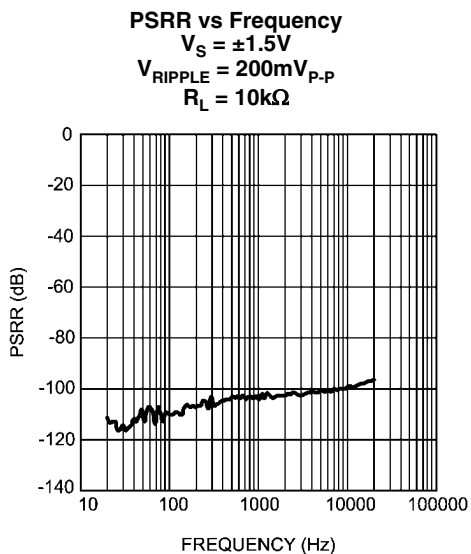

202049w3

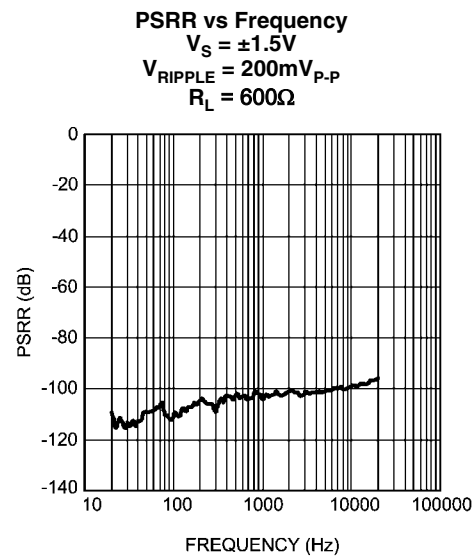

202049x4

PSRR vs Frequency

$V_S = \pm 2.5V$

$V_{RIPPLE} = 200mV_{P-P}$

$R_L = 2k\Omega$

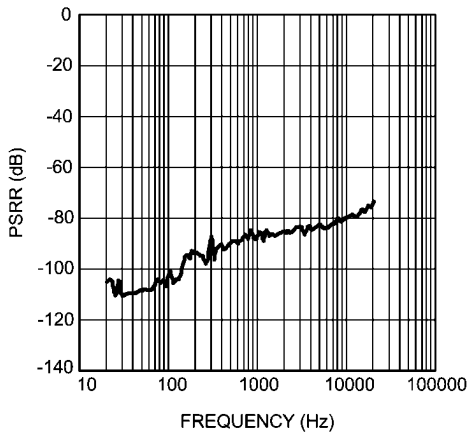

202049w5

PSRR vs Frequency

$V_S = \pm 2.5V$

$V_{RIPPLE} = 200mV_{P-P}$

$R_L = 10k\Omega$

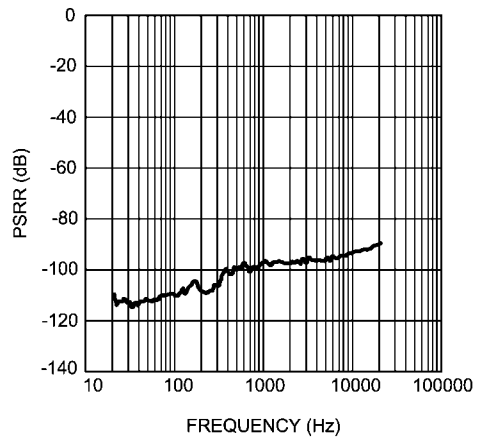

202049w6

PSRR vs Frequency

$V_S = \pm 2.5V$

$V_{RIPPLE} = 200mV_{P-P}$

$R_L = 600\Omega$

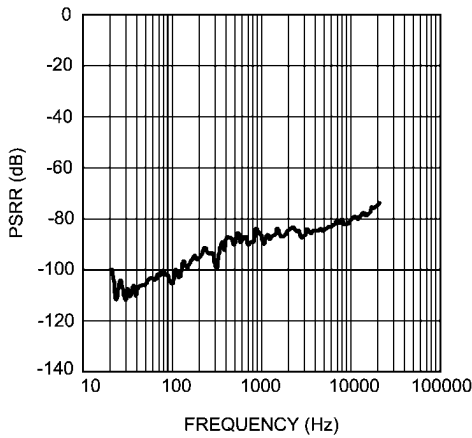

202049w7

PSRR vs Frequency

$V_S = \pm 2.75V$

$V_{RIPPLE} = 200mV_{P-P}$

$R_L = 2k\Omega$

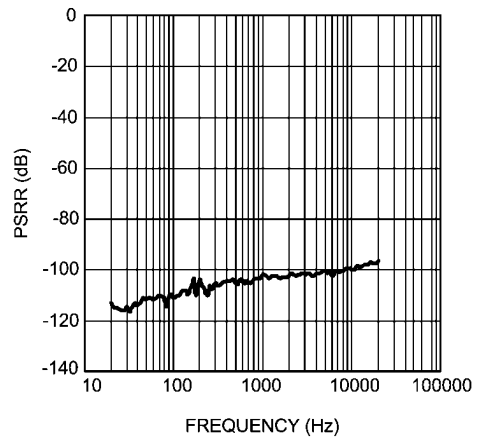

202049w8

PSRR vs Frequency

$V_S = \pm 2.75V$

$V_{RIPPLE} = 200mV_{P-P}$

$R_L = 10k\Omega$

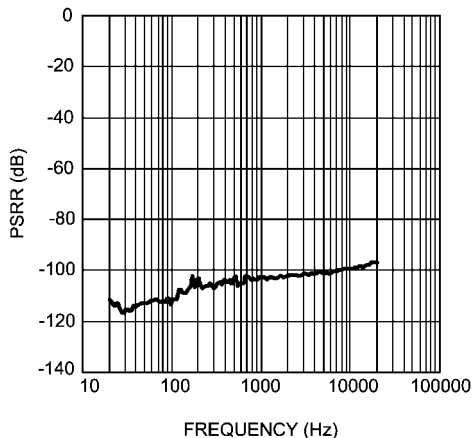

202049w9

PSRR vs Frequency

$V_S = \pm 2.75V$

$V_{RIPPLE} = 200mV_{P-P}$

$R_L = 600\Omega$

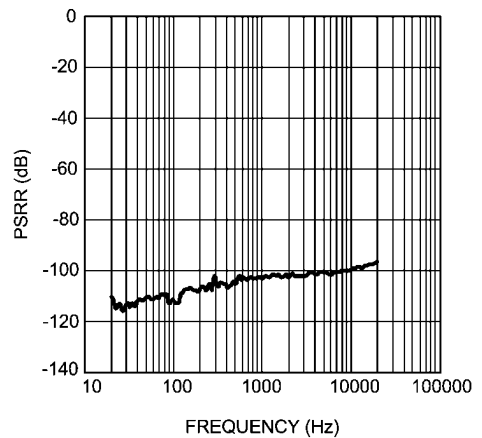

202049x0

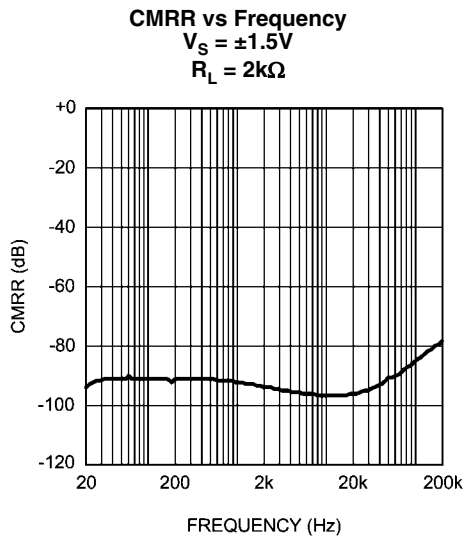

20204913

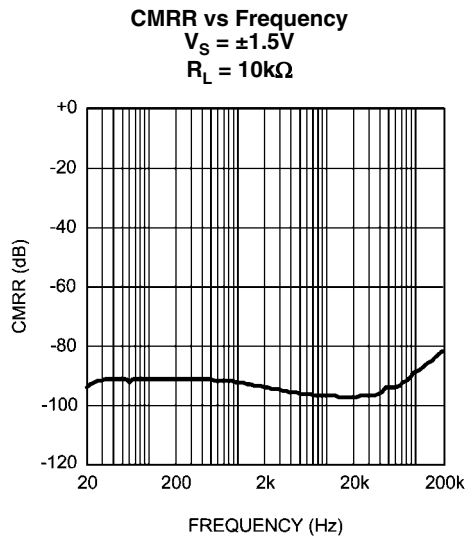

20204914

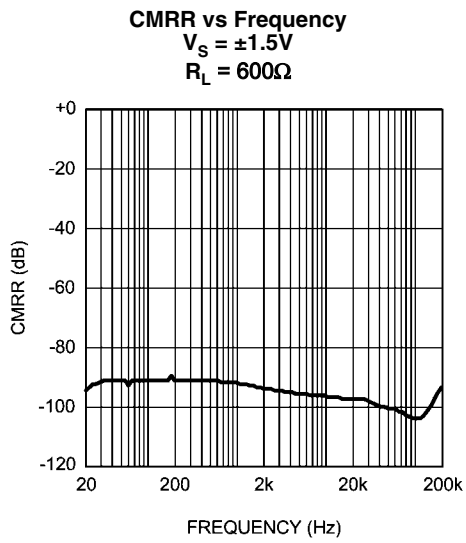

20204915

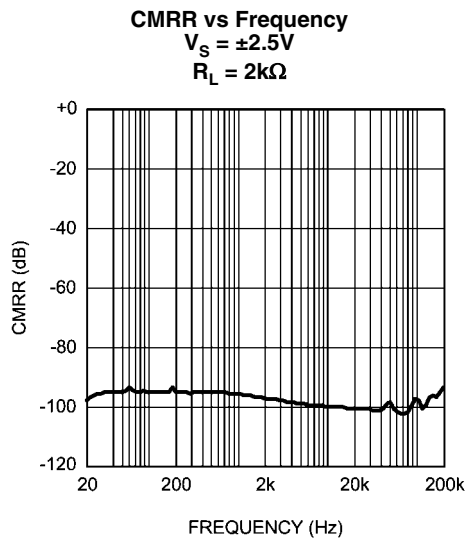

20204916

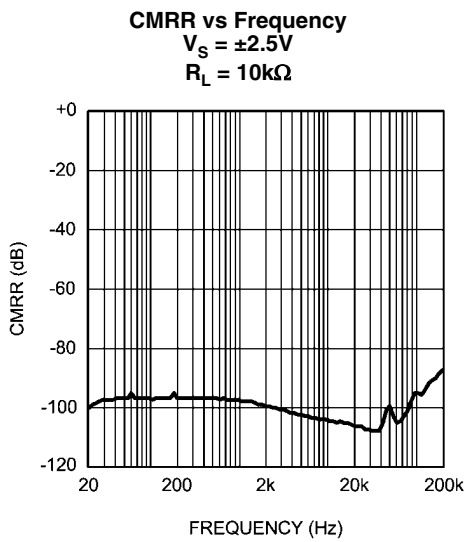

20204917

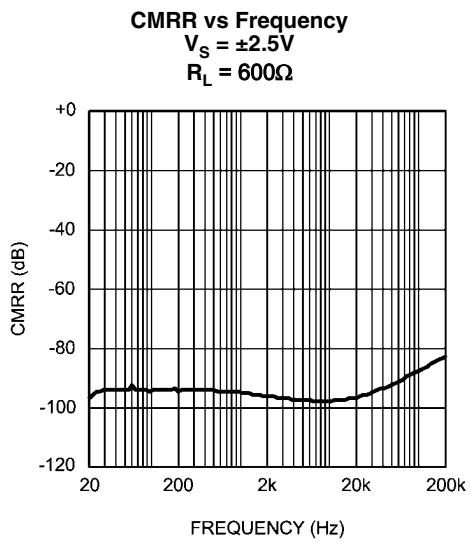

20204918

CMRR vs Frequency
 $V_S = \pm 2.75V$
 $R_L = 2k\Omega$

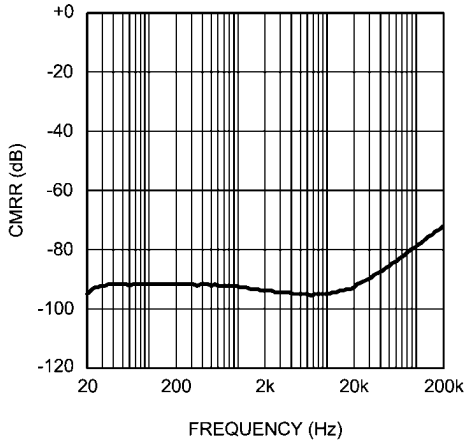

202049i9

CMRR vs Frequency
 $V_S = \pm 2.75V$
 $R_L = 10k\Omega$

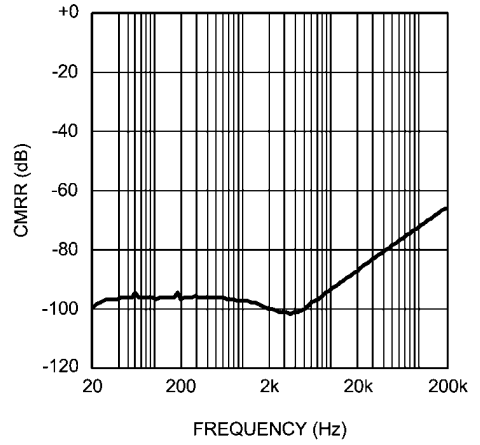

202049m0

CMRR vs Frequency
 $V_S = \pm 2.75V$
 $R_L = 600\Omega$

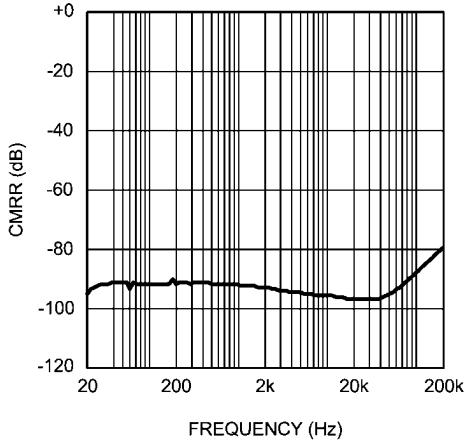

202049m1

Output Voltage Swing Neg vs Power Supply
 $R_L = 2k\Omega$

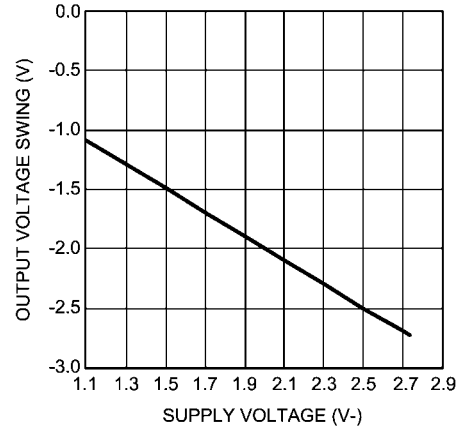

202049s9

Output Voltage Swing Neg vs Power Supply
 $R_L = 10k\Omega$

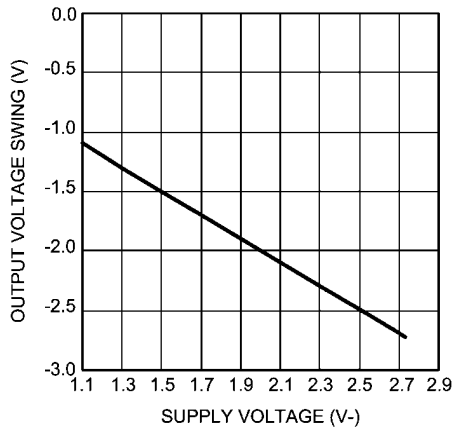

202049t0

Output Voltage Swing Neg vs Power Supply
 $R_L = 600\Omega$

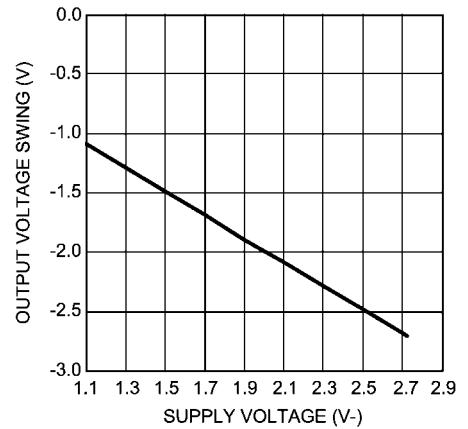

202049t1

Output Voltage Swing Pos vs Power Supply
 $R_L = 2k\Omega$

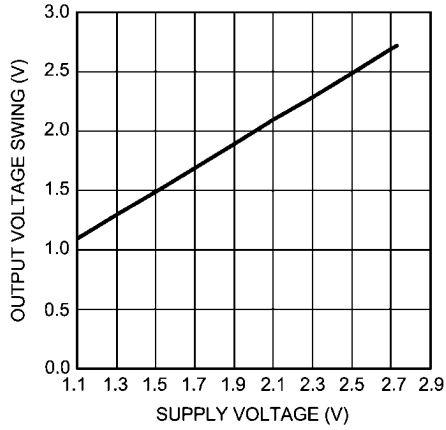

20204912

Output Voltage Swing Pos vs Power Supply
 $R_L = 10k\Omega$

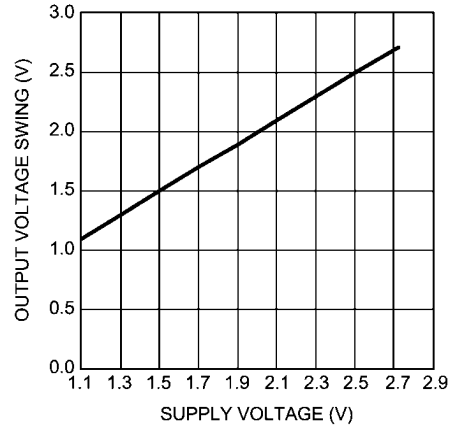

20204913

Output Voltage Swing Pos vs Power Supply
 $R_L = 600\Omega$

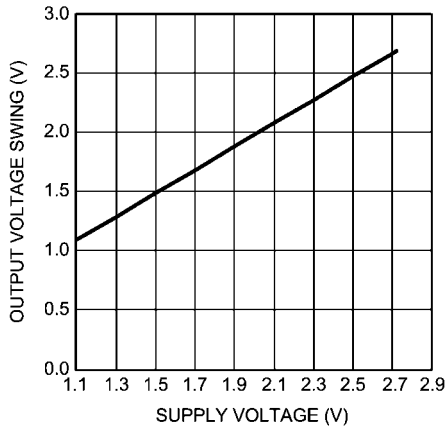

20204914

Supply Current per amplifier vs Power Supply
 $R_L = 2k\Omega$, Dual Supply

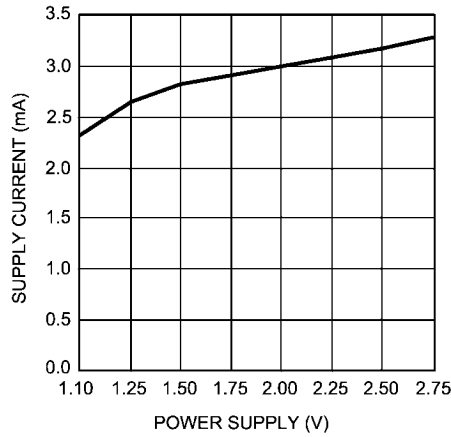

20204953

Supply Current per amplifier vs Power Supply
 $R_L = 10k\Omega$, Dual Supply

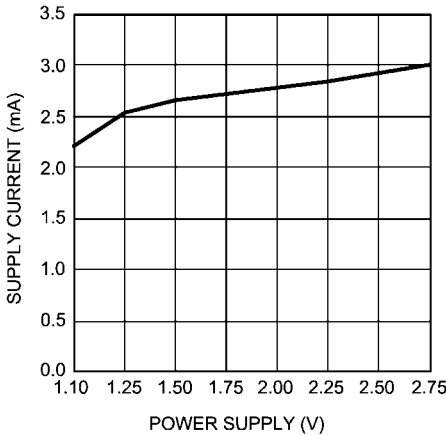

20204954

Supply Current per amplifier vs Power Supply
 $R_L = 600\Omega$, Dual Supply

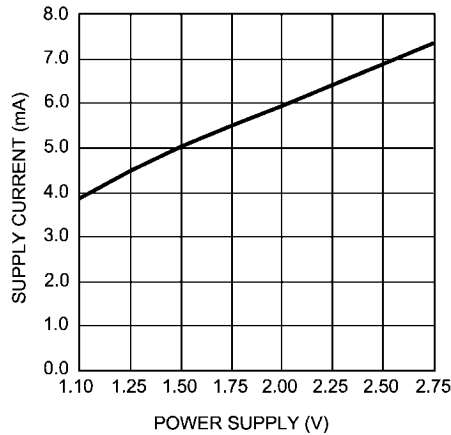

20204956

Application Information

DISTORTION MEASUREMENTS

The vanishingly low residual distortion produced by LME49721 is below the capabilities of all commercially available equipment. This makes distortion measurements just slightly more difficult than simply connecting a distortion meter to the amplifier's inputs and outputs. The solution, however, is quite simple: an additional resistor. Adding this resistor extends the resolution of the distortion measurement equipment.

The LME49721's low residual is an input referred internal error. As shown in Figure 1, adding the 10Ω resistor connected between the amplifier's inverting and non-inverting inputs

changes the amplifier's noise gain. The result is that the error signal (distortion) is amplified by a factor of 101. Although the amplifier's closed-loop gain is unaltered, the feedback available to correct distortion errors is reduced by 101. To ensure minimum effects on distortion measurements, keep the value of R_1 low as shown in Figure 1.

This technique is verified by duplicating the measurements with high closed loop gain and/or making the measurements at high frequencies. Doing so, produces distortion components that are within equipments capabilities. This datasheet's THD+N and IMD values were generated using the above described circuit connected to an Audio Precision System Two Cascade.

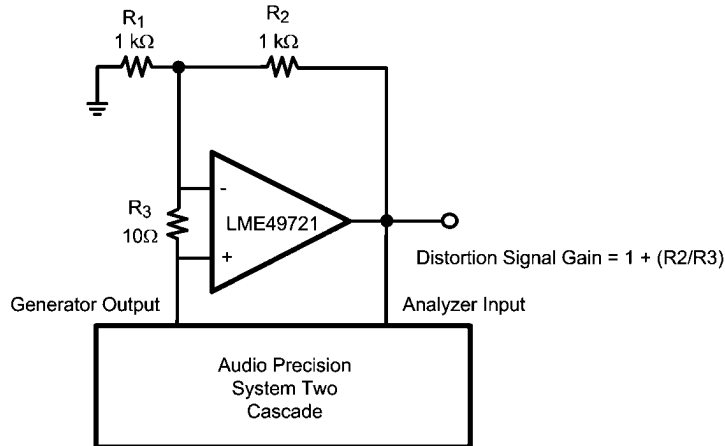

202049x2

FIGURE 1. THD+N and IMD Distortion Test Circuit with $A_v = 2$

OPERATING RATINGS AND BASIC DESIGN GUIDELINES

The LME49721 has a supply voltage range from +2.2V to +5.5V single supply or ± 1.1 to ± 2.75 V dual supply.

Bypassed capacitors for the supplies should be placed as close to the amplifier as possible. This will help minimize any inductance between the power supply and the supply pins. In addition to a $10\mu\text{F}$ capacitor, a $0.1\mu\text{F}$ capacitor is also recommended in CMOS amplifiers.

The amplifier's inputs lead lengths should also be as short as possible. If the op amp does not have a bypass capacitor, it may oscillate.

BASIC AMPLIFIER CONFIGURATIONS

The LME49721 may be operated with either a single supply or dual supplies. Figure 2 shows the typical connection for a single supply inverting amplifier. The output voltage for a single supply amplifier will be centered around the common-mode voltage V_{cm} . Note, the voltage applied to the V_{cm} insures the output stays above ground. Typically, the V_{cm}

should be equal to $V_{DD}/2$. This is done by putting a resistor divider ckt at this node, see Figure 2.

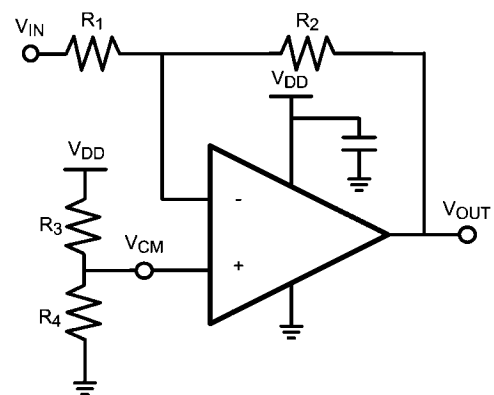

202049n3

FIGURE 2. Single Supply Inverting Op Amp

Figure 3 shows the typical connection for a dual supply inverting amplifier. The output voltage is centered on zero.

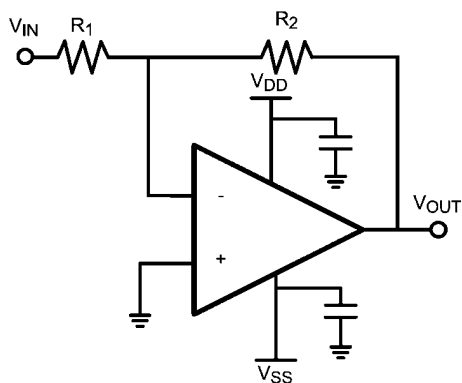

202049n2

FIGURE 3. Dual Supply Inverting Op Amp

Figure 4 shows the typical connection for the Buffer Amplifier or also called a Voltage Follower. A Buffer Amplifier can be used to solve impedance matching problems, to reduce pow-

er consumption in the source, or to drive heavy loads. The input impedance of the op amp is very high. Therefore, the input of the op amp does not load down the source. The output impedance on the other hand is very low. It allows the load to either supply or absorb energy to a circuit while a secondary voltage source dissipates energy from a circuit. The Buffer is a unity stable amplifier, $1V/V$. Although the feedback loop is tied from the output of the amplifier to the inverting input, the gain is still positive. Note, if a positive feedback is used, the amplifier will most likely drive to either rail at the output.

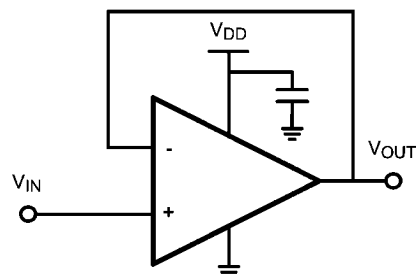

202049n1

FIGURE 4. Buffer

Typical Applications

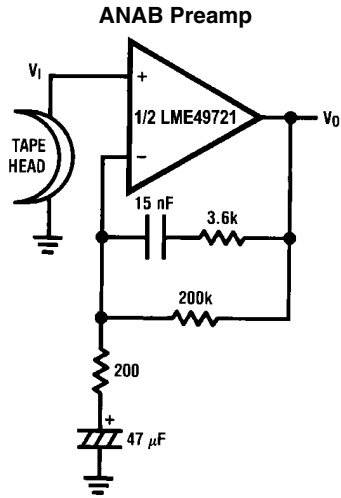

NAB Preamp Voltage Gain vs Frequency

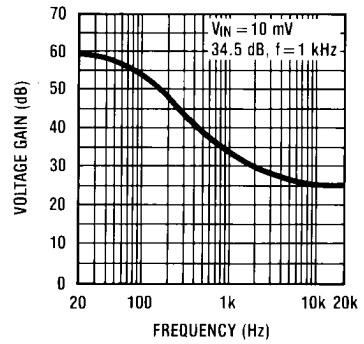

202049n5

$A_V = 34.5$
 $F = 1 \text{ kHz}$
 $E_n = 0.38 \mu\text{V}$
 A Weighted

202049n4

Balanced to Single Ended Converter

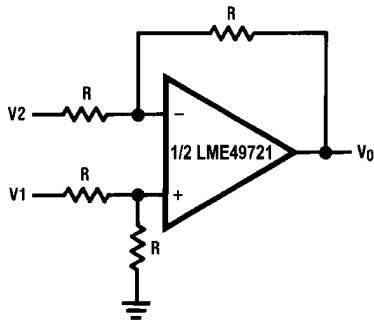

$V_O = V1 - V2$

202049n6

Adder/Subtractor

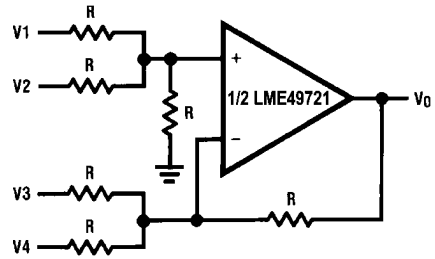

$V_O = V1 + V2 - V3 - V4$

202049n7

Sine Wave Oscillator

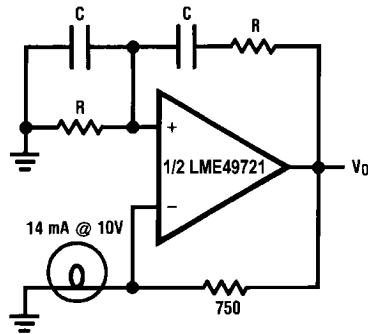

202049n8

$f_o = \frac{1}{2\pi RC}$

Second Order High Pass Filter (Butterworth)

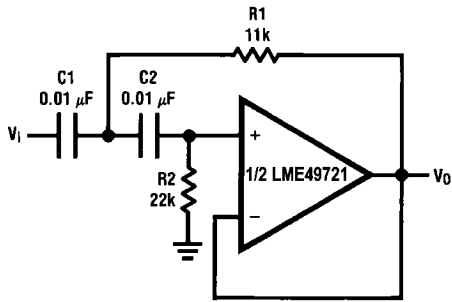

202049n9

if $C1 = C2 = C$

$$R1 = \frac{\sqrt{2}}{2\omega_0 C}$$

$$R2 = 2 \cdot R1$$

Illustration is $f_0 = 1 \text{ kHz}$

Second Order Low Pass Filter (Butterworth)

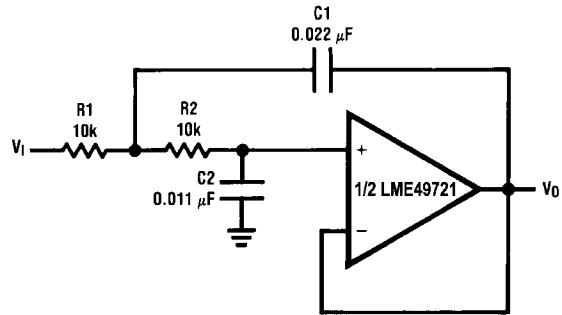

202049o0

if $R1 = R2 = R$

$$C1 = \frac{\sqrt{2}}{\omega_0 R}$$

$$C2 = \frac{C1}{2}$$

Illustration is $f_0 = 1 \text{ kHz}$

State Variable Filter

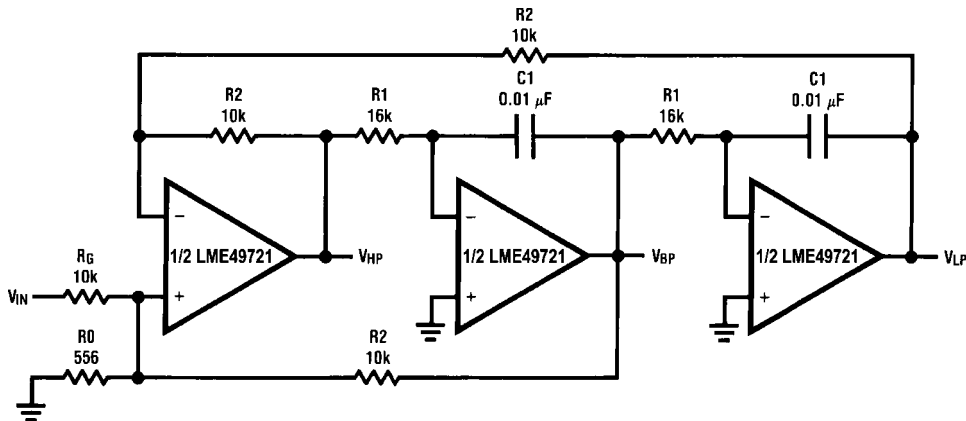

202049o1

$$f_0 = \frac{1}{2\pi C1 R1}, Q = \frac{1}{2} \left(1 + \frac{R2}{R0} + \frac{R2}{RG} \right), A_{BP} = Q A_{LP} = Q A_{LH} = \frac{R2}{RG}$$

Illustration is $f_0 = 1 \text{ kHz}, Q = 10, A_{BP} = 1$

AC/DC Converter

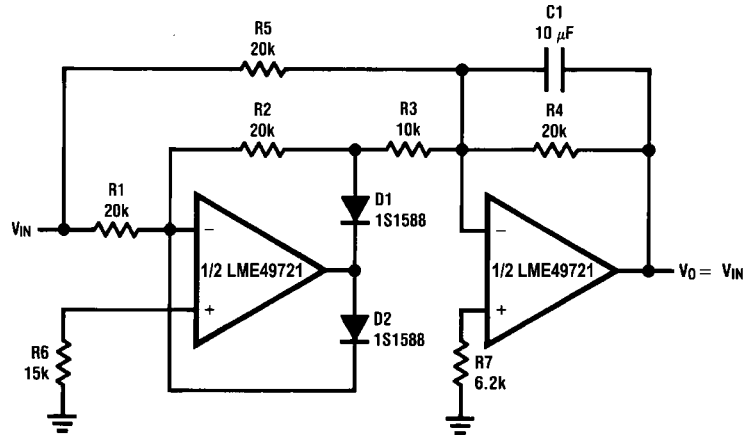

202049o2

2 Channel Panning Circuit (Pan Pot)

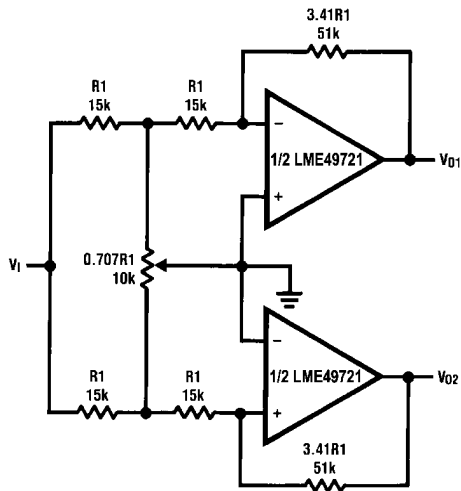

202049o3

Line Driver

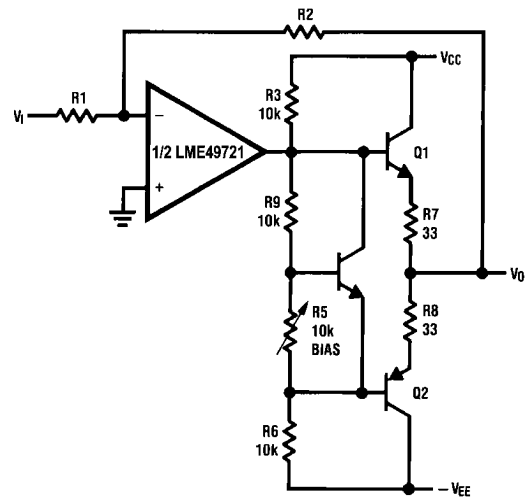

202049o4

Tone Control

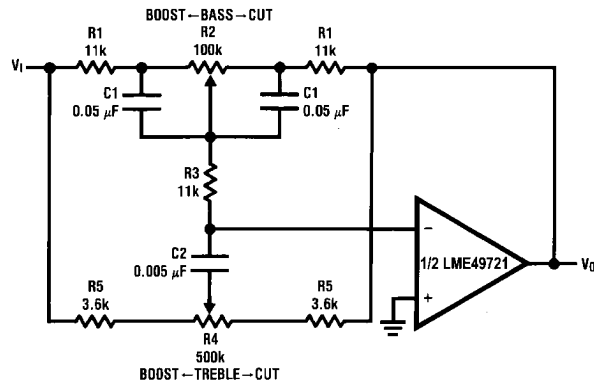

202049o5

$$f_L = \frac{1}{2\pi R_2 C_1}, f_{LB} = \frac{1}{2\pi R_1 C_1}$$

$$f_H = \frac{1}{2\pi R_5 C_2}, f_{HB} = \frac{1}{2\pi (R_1 + R_5 + 2R_3) C_2}$$

Illustration is:

$f_L = 32 \text{ Hz}$, $f_{LB} = 320 \text{ Hz}$
 $f_H = 11 \text{ kHz}$, $f_{HB} = 1.1 \text{ kHz}$

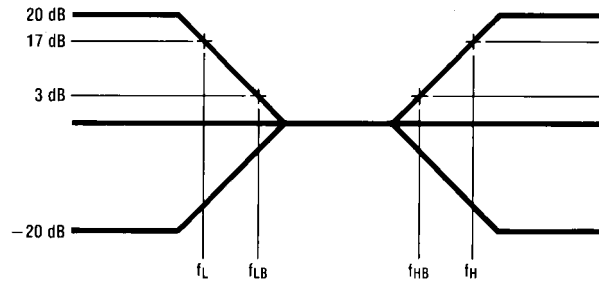

202049o6

RIIA Preamp

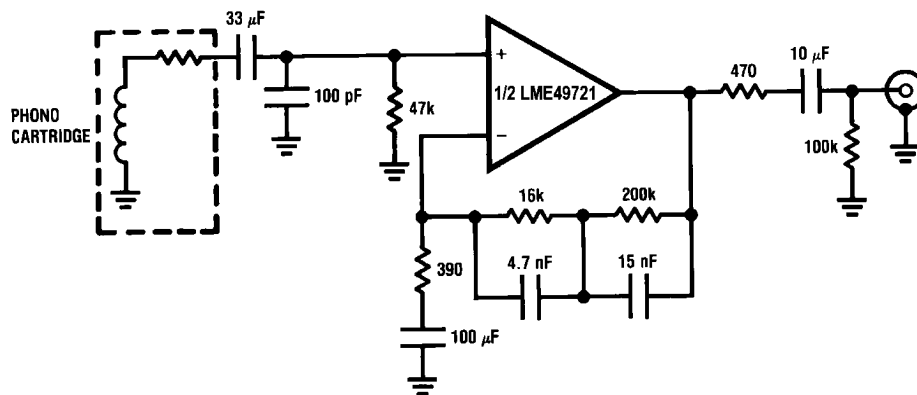

202049o8

$A_v = 35 \text{ dB}$
 $E_n = 0.33 \mu\text{V}$
 $S/N = 90 \text{ dB}$
 $f = 1 \text{ kHz}$
 A Weighted
 A Weighted, $V_{IN} = 10 \text{ mV}$
 @ $f = 1 \text{ kHz}$

Balanced Input Mic Amp

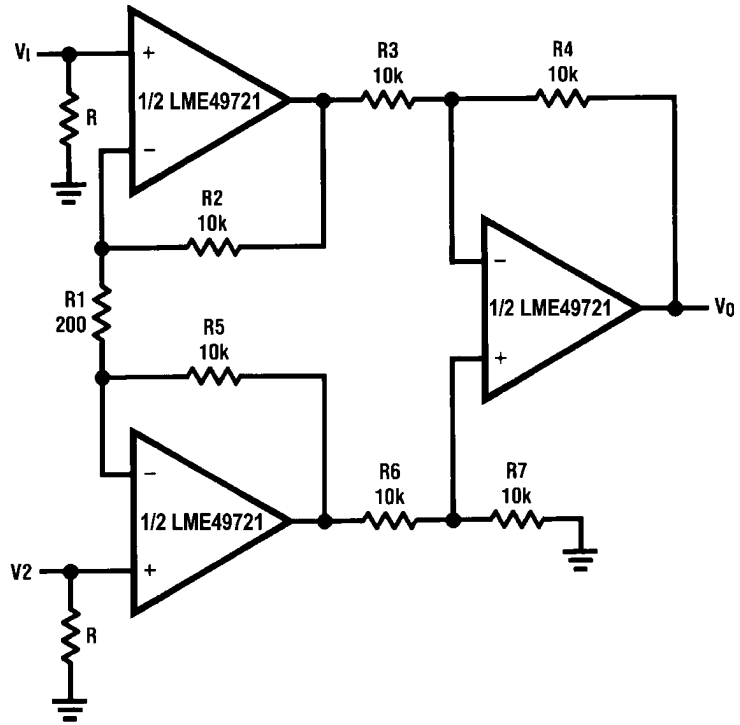

20204907

If $R_2 = R_5$, $R_3 = R_6$, $R_4 = R_7$

$$V_0 = \left(1 + \frac{2R_2}{R_1}\right) \frac{R_4}{R_3} (V_2 - V_1)$$

Illustration is:

$$V_0 = 101(V_2 - V_1)$$

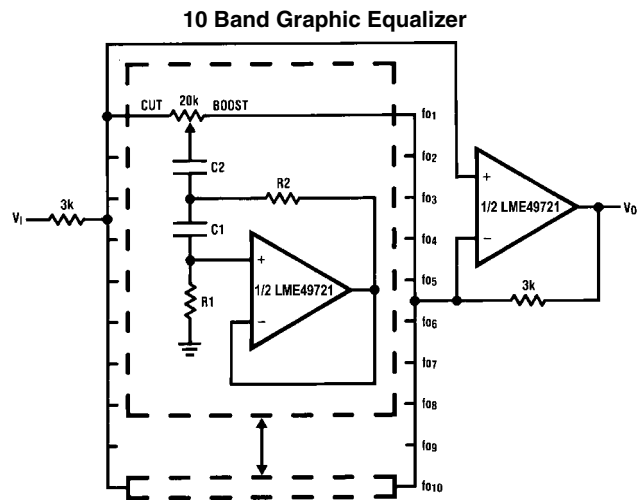

202049p0

fo (Hz)	C ₁	C ₂	R ₁	R ₂
32	0.12 μ F	4.7 μ F	75k Ω	500 Ω
64	0.056 μ F	3.3 μ F	68k Ω	510 Ω
125	0.033 μ F	1.5 μ F	62k Ω	510 Ω
250	0.015 μ F	0.82 μ F	68k Ω	470 Ω
500	8200pF	0.39 μ F	62k Ω	470 Ω
1k	3900pF	0.22 μ F	68k Ω	470 Ω
2k	2000pF	0.1 μ F	68k Ω	470 Ω
4k	1100pF	0.056 μ F	62k Ω	470 Ω
8k	510pF	0.022 μ F	68k Ω	510 Ω
16k	330pF	0.012 μ F	51k Ω	510 Ω

Note 8: At volume of change = ± 12 dB

Q = 1.7

Reference: "AUDIO/RADIO HANDBOOK", National Semiconductor, 1980, Page 2-61

Revision History

Rev	Date	Description
1.0	09/26/07	Initial release.
1.1	10/01/07	Input more info under the Buffer Amplifier.

Physical Dimensions inches (millimeters) unless otherwise noted

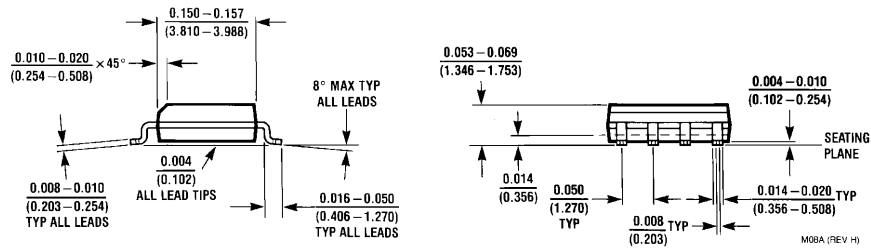
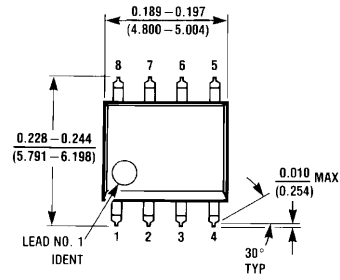

NS Package M08A

M08A (REV H)

Notes

THE CONTENTS OF THIS DOCUMENT ARE PROVIDED IN CONNECTION WITH NATIONAL SEMICONDUCTOR CORPORATION ("NATIONAL") PRODUCTS. NATIONAL MAKES NO REPRESENTATIONS OR WARRANTIES WITH RESPECT TO THE ACCURACY OR COMPLETENESS OF THE CONTENTS OF THIS PUBLICATION AND RESERVES THE RIGHT TO MAKE CHANGES TO SPECIFICATIONS AND PRODUCT DESCRIPTIONS AT ANY TIME WITHOUT NOTICE. NO LICENSE, WHETHER EXPRESS, IMPLIED, ARISING BY ESTOPPEL OR OTHERWISE, TO ANY INTELLECTUAL PROPERTY RIGHTS IS GRANTED BY THIS DOCUMENT.

TESTING AND OTHER QUALITY CONTROLS ARE USED TO THE EXTENT NATIONAL DEEMS NECESSARY TO SUPPORT NATIONAL'S PRODUCT WARRANTY. EXCEPT WHERE MANDATED BY GOVERNMENT REQUIREMENTS, TESTING OF ALL PARAMETERS OF EACH PRODUCT IS NOT NECESSARILY PERFORMED. NATIONAL ASSUMES NO LIABILITY FOR APPLICATIONS ASSISTANCE OR BUYER PRODUCT DESIGN. BUYERS ARE RESPONSIBLE FOR THEIR PRODUCTS AND APPLICATIONS USING NATIONAL COMPONENTS. PRIOR TO USING OR DISTRIBUTING ANY PRODUCTS THAT INCLUDE NATIONAL COMPONENTS, BUYERS SHOULD PROVIDE ADEQUATE DESIGN, TESTING AND OPERATING SAFEGUARDS.

EXCEPT AS PROVIDED IN NATIONAL'S TERMS AND CONDITIONS OF SALE FOR SUCH PRODUCTS, NATIONAL ASSUMES NO LIABILITY WHATSOEVER, AND NATIONAL DISCLAIMS ANY EXPRESS OR IMPLIED WARRANTY RELATING TO THE SALE AND/OR USE OF NATIONAL PRODUCTS INCLUDING LIABILITY OR WARRANTIES RELATING TO FITNESS FOR A PARTICULAR PURPOSE, MERCHANTABILITY, OR INFRINGEMENT OF ANY PATENT, COPYRIGHT OR OTHER INTELLECTUAL PROPERTY RIGHT.

LIFE SUPPORT POLICY

NATIONAL'S PRODUCTS ARE NOT AUTHORIZED FOR USE AS CRITICAL COMPONENTS IN LIFE SUPPORT DEVICES OR SYSTEMS WITHOUT THE EXPRESS PRIOR WRITTEN APPROVAL OF THE CHIEF EXECUTIVE OFFICER AND GENERAL COUNSEL OF NATIONAL SEMICONDUCTOR CORPORATION. As used herein:

Life support devices or systems are devices which (a) are intended for surgical implant into the body, or (b) support or sustain life and whose failure to perform when properly used in accordance with instructions for use provided in the labeling can be reasonably expected to result in a significant injury to the user. A critical component is any component in a life support device or system whose failure to perform can be reasonably expected to cause the failure of the life support device or system or to affect its safety or effectiveness.

National Semiconductor and the National Semiconductor logo are registered trademarks of National Semiconductor Corporation. All other brand or product names may be trademarks or registered trademarks of their respective holders.

Copyright© 2007 National Semiconductor Corporation

For the most current product information visit us at www.national.com



**National Semiconductor
Americas Customer
Support Center**
Email:
new.feedback@nsc.com
Tel: 1-800-272-9959

**National Semiconductor Europe
Customer Support Center**
Fax: +49 (0) 180-530-85-86
Email: europe.support@nsc.com
Deutsch Tel: +49 (0) 69 9508 6208
English Tel: +49 (0) 870 24 0 2171
Français Tel: +33 (0) 1 41 91 8790

**National Semiconductor Asia
Pacific Customer Support Center**
Email: ap.support@nsc.com

**National Semiconductor Japan
Customer Support Center**
Fax: 81-3-5639-7507
Email: jpn.feedback@nsc.com
Tel: 81-3-5639-7560